

1500 Gallon
2 Compartment Tank

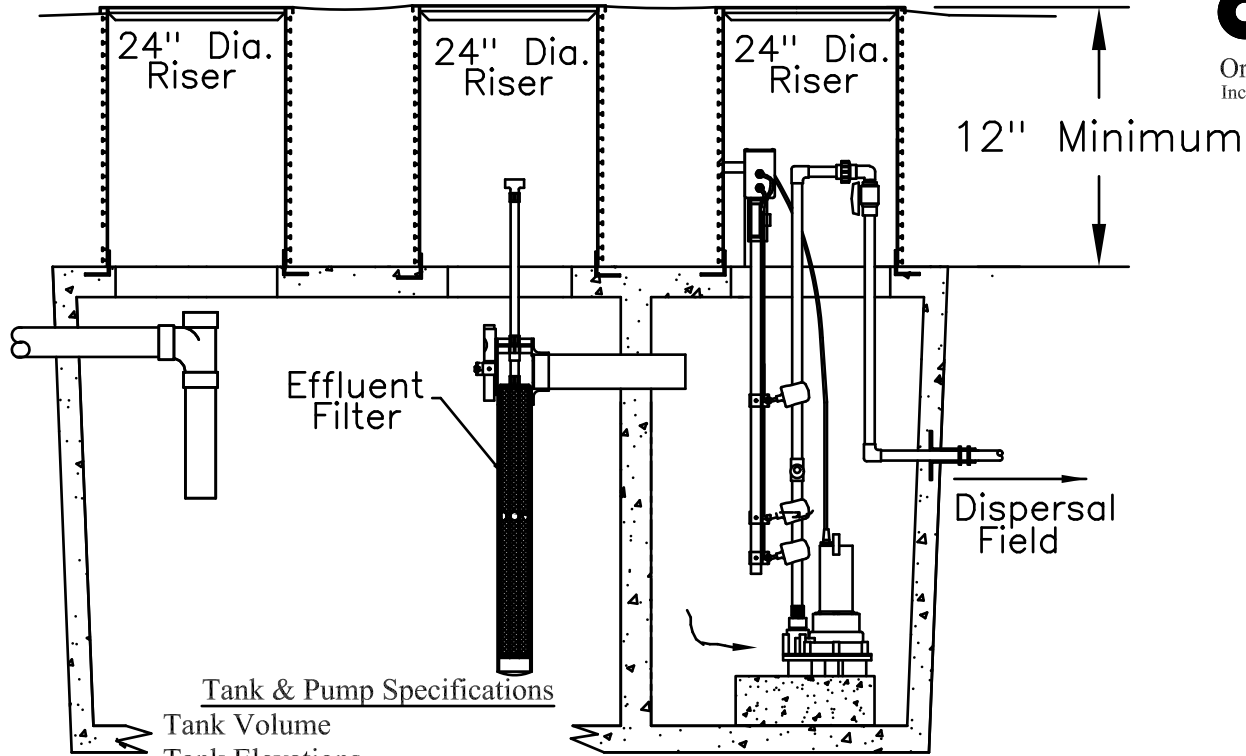

Tank & Pump Specifications

- Tank Volume _____
- Tank Elevations
- Riser Lid _____
- Tank Top (outside) _____
- Inlet Invert _____
- Outlet Invert _____
- Tank Bottom _____

Pump Description

- Make _____
- Model _____
- GPM @ TDH _____
- HP _____
- Voltage/Phase _____
- Dose Volume _____
- Pump Vault Model _____
- Dischrge Assembly Model _____
- Float Model _____
- Control Panel Model _____

Water Tight Tankage Spec.
It Is Necessary That Tanks Be Vacuum Or Water Tested To Certify Water Tight Tankage. PVC Acces Risers Must Be Water Tight, Epoxied To Tankage And Lids Bolted Down For Liability Consideration. Contractor/Tank Manufacturer Shall Be Responsible For Repair Or Replacement Of Tanks With Leaks or Defects. Tankage Must Have 3 Year Warranty

Step System
Septic Tank Effluent Pump
Model: Step LH (2 COMP)

DRAWN	jdu
SCALE	
DATE	12/20/04
APPROVED	

7125 East Pickard Road
P. O. Box 309
Mt. Pleasant, MI 48804-0309
ph-989-773-9938
fax-989-772-3415



NO	REVISION	DATE	BY
1.	12/04		Jdu
2.	6/08		SLB
3.			
4.			
5.			

SHEET	1
OF	1

DRAWING NO. S7