

Water Tight Tankage Spec.
 It Is Necessary That Tanks
 Be Vacuum Or Water Tested
 To Certify Water Tight Tankage.
 PVC Acces Risers Must Be
 Water Tight, Epoxied To Tankage
 And Lids Bolted Down For Liability
 Consideration. Contractor/Tank
 Manufacturer Shall Be Responsible
 For Repair Or Replacement
 Of Tanks With Leaks Or Defects.
 Tankage Must Have 3 Year Warranty

Patents # 4,439,323 & 5,492,635
 Foreign Patents Pending
 © Orenco Systems, Inc.

Note: AdvanTex
 Piping Must
 Not Settle

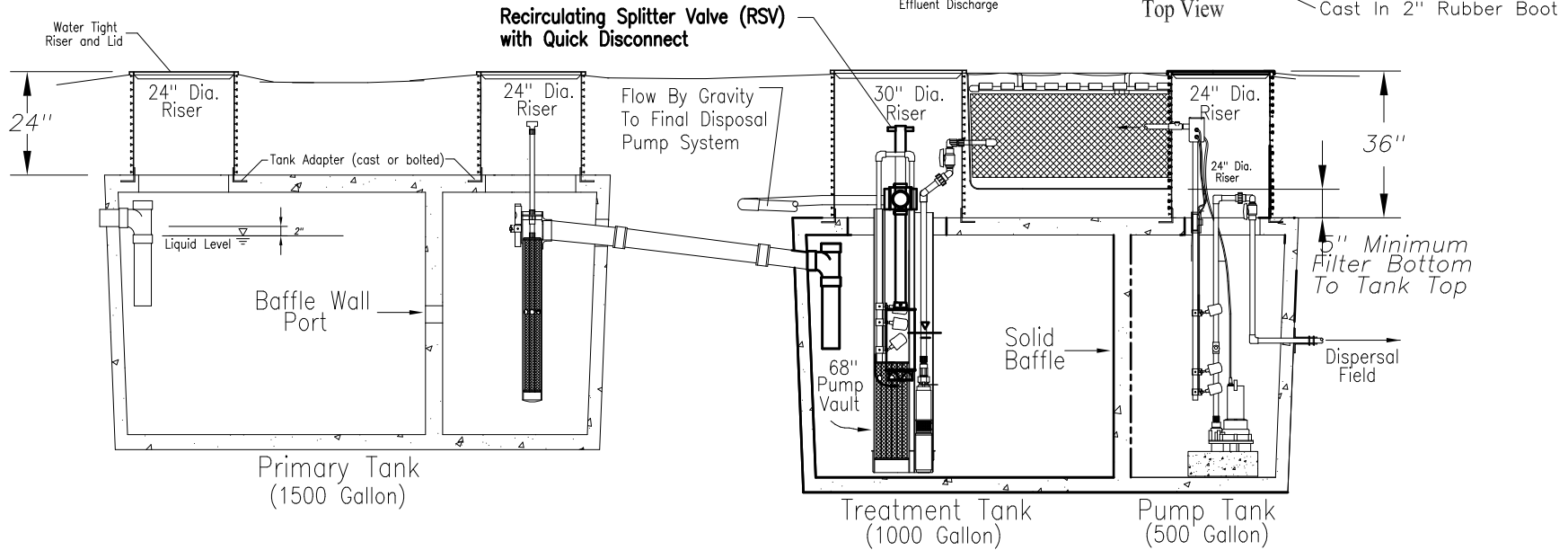
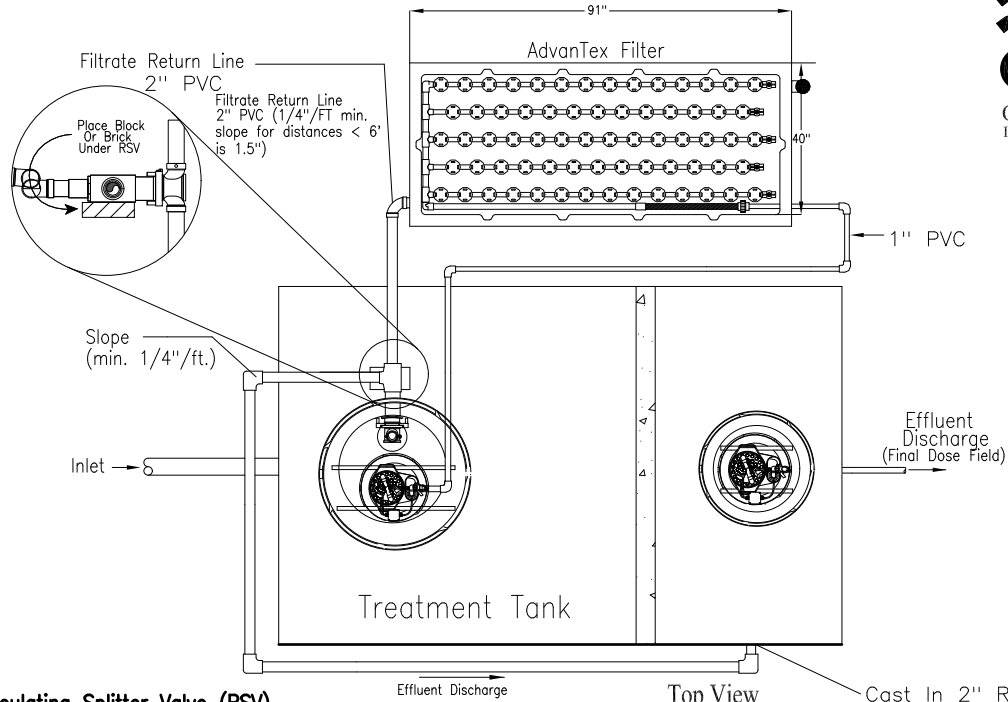

AdvanTex™ Treatment System
AX 20 Series - Mode 1b

AX 20 b 1500 1500 LH

DRAWN	jdu
SCALE	
DATE	12/20/04
APPROVED	

7125 East Pickard Road
 P. O. Box 309
 Mt. Pleasant, MI 48804-0309
 ph-989-773-9938
 fax-989-772-3415



BY	jdu	SLB			
DATE					
REVISION	12/04	6/08			

NO	1.	2.	3.	4.	5.
SHEET					
				1	
				OF	

DRAWING NO.
 AX-P-LH